

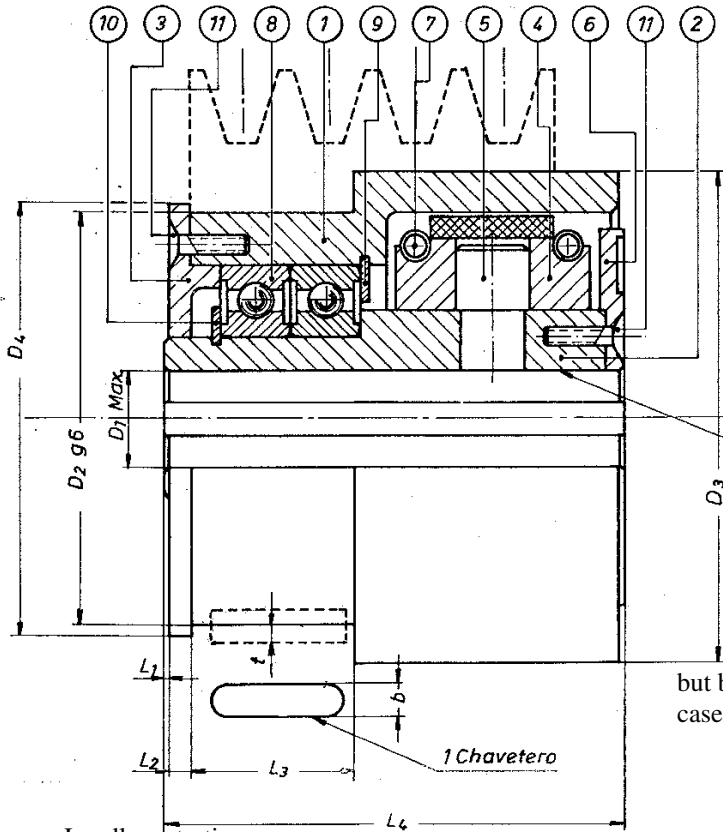

**“A “ SERIES LOADLESS STARTING CENTRIFUGAL AUTOMATIC CLUTCH
(FOR PULLEY)**



SPARE PARTS IDENTIFICATION	
1:	SLEEVE
2:	CORE
3:	LID
4:	MASS
5:	DRAGGING BOLT
6:	LID
7:	SPRING
8:	BEARING
9:	SEEGER RING
10:	SEEGER RING
11:	SCREW

Acceleration time can be adjusted by adding or removing centrifugal mass, depending on if we want either to shorten or to lengthen that time

KEYSEATS ACCORDING TO DIN 6885

Our units are delivered without drilling nor notching, but both of them can be done, by adding their additional cost, in case they are required by the customer.

- Loadless starting
- Avoids failures due to overloads or clogging.
- Allow less powerful engines to be used.

- Electrical accessories are no longer needed.
- For explosion engines, they can be automatically disconnected when idling.

Size	DIAMETERS(mm)				LENGTHS (mm)				Pulley fixing	
	Max D1	g6 D2	D3	D4	L1	L2	L3	L4	b	T
A0	18	75	90	80	1	4	29	85	6	2.5
A1	25	90	104	95	1	5	33	96	6	2.5
A2	30	95	115	100	1	6	37	106	6	2.5

Size	MAXIMUM POWER (KW) FOR SEVERAL ROTATIVE SPEEDS (RPM)															
	750	950	1200	1450	1700	1900	2000	2250	2500	2700	2900	3000	3200	3500	3800	4000
A0		0.108	0.217	0.368	0.6	0.88	1.03	1.47	1.99	2.13	2.28	2.35	2.5	2.8	2.94	3.16
A1	0.147	0.294	0.59	1.10	1.66	2.35	2.65	3.31	3.68	4.05	4.34	4.42	4.78	5.15	5.67	5.88
A2	0.18	0.368	0.83	1.47	2.39	3.31	3.86	5.52	7.36	7.87	8.53	8.83	9.35	10.31	11.04	11.78

Powers shown in the tables can have 20% overloads. For harder applications ask our technical department.

If clutches are used as torque limiters and must be exposed to long slipping periods, you should ask our technical department so that, after analysing the heat dissipation, they can choose the most suitable mechanism.